

PRK18B

Tracking retro-reflective sensor for bottles and tape

en 04-2017/06 50121190-03



Dimensioned drawing

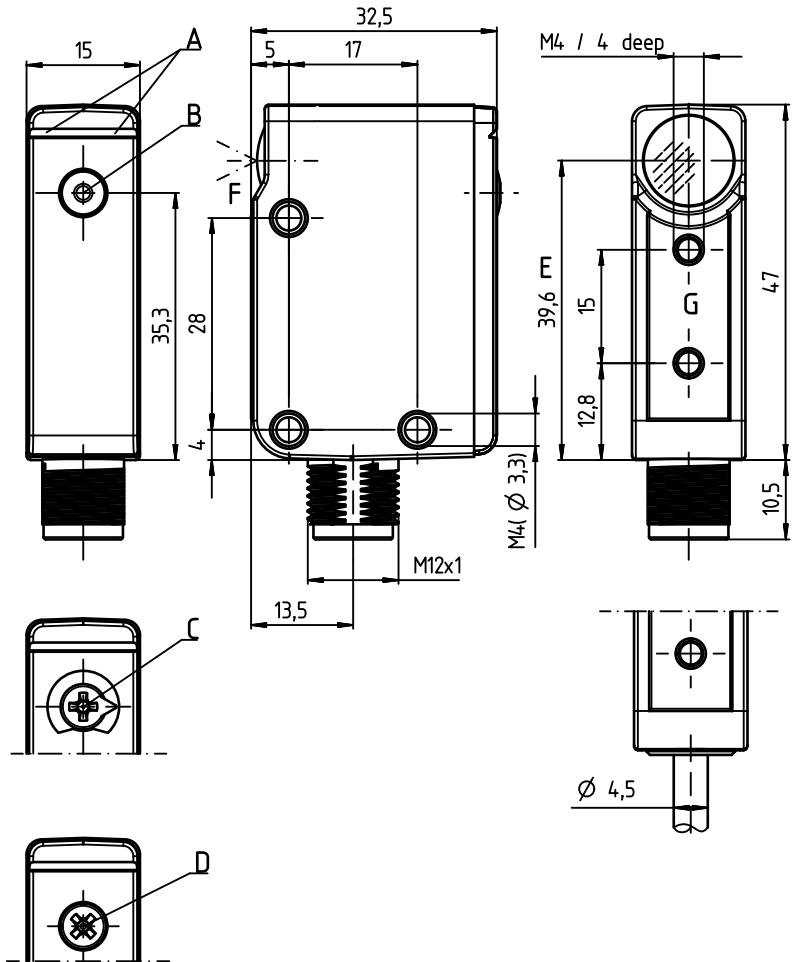

- A Display
- B Teach button
- C 270° potentiometer
- D 11-turn potentiometer
- E Optical axis
- F Optical accuracy
- G Reference plane for F

Electrical connection

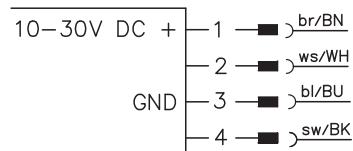

- Retro-reflective photoelectric sensors with autocollimation optics for reliable detection of highly transparent bottles and tape
- Sensitivity adjustment via teach button
- Temperature compensation $\pm 20^{\circ}\text{C}$
- Automatic contamination compensation (tracking function) for longer intervals between cleanings

Accessories:

(available separately)

- Mounting system (BTU 200, BT 95)
- M12 connection technology (K-D M12)
- Reflectors (TK, MTK)
- Reflective tape (REF)
- Deflecting mirrors (US18B)

	Pin 1	Pin 2	Pin 3	Pin 4
PRK18B.TT3/4P-M12	+	PNP dark	GND	PNP light
PRK18B.TT3/4P-M12	+	PNP light	GND	PNP dark
PRK18B.XTT3/4P-M12	+	PNP dark	GND	PNP light
PRK18B.TT3/2N-M12	+	NPN dark	GND	NPN light
PRK18B.TT3/6G-M12	+	Push-Pull (PNP dark, NPN light)	GND	Push-Pull (PNP light, NPN dark)

We reserve the right to make changes • PAL_PRK18BTT_en_50121190_03.fm

Specifications

Optical data

Typ. op. range limit (TK(S) 100x100) ¹⁾	0 ... 3.6m
Operating ranges ²⁾	see tables
Light source ³⁾	LED (modulated light)
Wavelength	620nm (visible red light)
Optical accuracy	type dependent (see order guide)

Timing

Switching frequency	1500Hz
Response time	0.333ms
Jitter time	110µs
Delay before start-up	< 300ms

Electrical data

Operating voltage UB ⁴⁾	10 ... 30VDC (incl. residual ripple)
Residual ripple	≤ 15% of UB
Open-circuit current	≤ 18mA
Switching outputs/functions	/6G 2 push-pull switching outputs pin 2: PNP dark switching, NPN light switching pin 4: PNP light switching, NPN dark switching
	/4P 2 PNP switching outputs, antivalent, pin 2: dark switching, pin 4: light switching
	/P4 2 PNP switching outputs, antivalent, pin 2: light switching, pin 4: dark switching
	/4X 1 PNP switching output, light switching
	/PX 1 PNP switching output, dark switching
	/2N 2 NPN switching outputs, antivalent
	/2X 1 NPN switching output, light switching
	/NX 1 NPN switching output, dark switching
Signal voltage high/low	≥ (UB-2V) ≤ 2V
Output current	max. 100mA
Sensitivity	adjustable via teach button (see order guide)

Indicators

Green LED	ready
Yellow LED	light path free
Yellow/green LED, flashing synchronously (9Hz)	error

Mechanical data

Housing ⁵⁾	diecast zinc, chemically nickel-plated
Connector	diecast zinc, chemically nickel-plated
Optics	glass
Operation	teach button
Weight	with M12 connector: 60g with 6000mm cable: 240g
Connection type	M12 connector, 4-pin cable 6000mm, 4 x 0.20mm ²

Environmental data

Ambient temp. (operation/storage)	-40°C ... +60°C / -40°C ... +70°C
Protective circuit ⁶⁾	2, 3
VDE safety class ⁷⁾	III
Protection class	IP67, IP 69K
Light source	exempt group (in acc. with EN 62471)
Standards applied	IEC 60947-5-2
Certifications	UL 508, C22.2 No.14-13 ⁴⁾ ⁸⁾
Chemical resistance	tested in accordance with ECOLAB

- 1) Typ. operating range limit: max. attainable range without performance reserve
- 2) Operating range: recommended range with performance reserve
- 3) Average life expectancy 100,000h at an ambient temperature of 25°C
- 4) For UL applications: for use in class 2 circuits according to NEC only
- 5) Color changes due to cleaning agents do not adversely affect the coating
- 6) 2=polarity reversal protection, 3=short circuit protection for all transistor outputs
- 7) Rating voltage 50V
- 8) These proximity switches shall be used with UL Listed Cable assemblies rated 30V, 0.24A min, in the field installation, or equivalent (categories: CYJV/CYJV7 or PVVA/PVVA7)

UL REQUIREMENTS

Enclosure Type Rating: Type 1

For Use in NFPA 79 Applications only.

Adapters providing field wiring means are available from the manufacturer. Refer to manufacturers information.

CAUTION – the use of controls or adjustments or performance of procedures other than those specified herein may result in hazardous radiation exposure.

ATTENTION ! Si d'autres dispositifs d'alignement que ceux préconisés ici sont utilisés ou s'il est procédé autrement qu'indiqué, cela peut entraîner une exposition à des rayonnements et un danger pour les personnes.

Tables

Reflectors	Operating range
1 TK(S) 100x100	0 ... 3.0m
2 MTKS 50x50.1	0 ... 2.8m
3 TK(S) 40x60	0 ... 2.5m
4 TK(S) 30x50	0 ... 1.1m
5 TK(S) 20x40	0 ... 1.1m
6 Tape 6 50x50	0 ... 1.0m

1	0	3.0	3.6
2	0	2.8	3.3
3	0	2.5	3.0
4	0	1.1	1.3
5	0	1.1	1.3
6	0	1.0	1.2

□ Operating range [m]
 ▒ Typ. operating range limit [m]

TK ... = adhesive
 TK(S) ... = screw type
 Tape 6 = adhesive

Diagrams

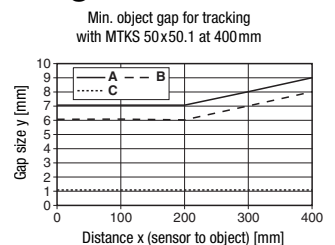

- A 11% sensor sensitivity
- B 18% sensor sensitivity
- C 100% sensor sensitivity

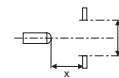

Remarks

Operate in accordance with intended use!

- ⚠ This product is not a safety sensor and is not intended as personnel protection.
- ⚠ The product may only be put into operation by competent persons.
- ⚠ Only use the product in accordance with the intended use.

● Reflectors:

The light spot may not extend beyond the reflector. Preferably use MTK(S) reflectors or reflective tape 6.

PRK18B

Tracking retro-reflective sensor for bottles and tape

Part number code

P R K 1 8 B . F X T T 3 / 4 P - M 1 2

Operating principle

- PRK** Retro-reflective photoelectric sensor for bottles
RK Retro-reflective photoelectric sensor for tape
 (Function against any reflective tapes and glass triple reflectors)

Series

- 18B** 18B series

Timing

- F** High speed
free Standard

Optical accuracy

- X** Optical axis aligned, shift angle $< \pm 0.25^\circ$
free Standard

Detection properties

- T** Setting of 11% is possible
free Setting of 11% is not possible

Tracking function available

- T 1)** Tracking function/contamination compensation
free No tracking function

Setting

- 1** 270° potentiometer
2 11-turn potentiometer
3 Teach button
free No setting

Pin assignment of connector pin 4 / black cable wire

- 2** NPN, light switching
N NPN, dark switching
4 PNP, light switching
P PNP, dark switching
6 Push-Pull (PNP light switching, NPN dark switching)
G Push-Pull (PNP dark switching, NPN light switching)
L IO-Link

Pin assignment of connector pin 2 / white cable wire

- X** Not assigned
2 NPN, light switching
N NPN, dark switching
4 PNP, light switching
P PNP, dark switching
6 Push-Pull (PNP light switching, NPN dark switching)
G Push-Pull (PNP dark switching, NPN light switching)
T Teach input

Connection technology

- M12** M12 connector, 4-pin
6000 Cable 6 m

1) Only possible in conjunction with the detection property "T".

Order guide

The sensors listed here are preferred types; current information at www.leuze.com.

Selection table		Order code →	PRK18B.TT3/4P-M12 Part no. 50121229	PRK18B.TT3/P4-M12 Part no. 50126940	PRK18B.XTT3/4P-M12 Part no. 50124943	PRK18B.TT3/2N-M12 Part no. 50121228	PRK18B.TT3/6G-M12 Part no. 50132521
Equipment ↓							
Switching output	1 x PNP, light switching						
	1 x PNP, dark switching						
	2 x PNP, antivalent, pin 2: dark switching, pin 4: light switching		●		●		
	2 x PNP, antivalent, pin 2: light switching, pin 4: dark switching			●			
	1 x NPN, dark switching						
	2 x NPN, antivalent					●	
	2 x push-pull switching output						●
	1 x IO-Link, 1 x PNP, dark switching						
	1 x IO-Link, 1 x NPN, dark switching						
Optical accuracy	calibrated $\leq \pm 0.25^\circ$			●			
Switching frequency/response time/jitter	500Hz/1 ms/320µs						
	1500Hz/333µs/110µs		●	●	●	●	●
	5000Hz/100µs/32µs						
Detection properties	highly transparent bottles and glasses		●	●	●	●	●
	highly transparent tape < 20µm thick						
	transparent containers		●	●	●	●	●
Tracking function	exists		●	●	●	●	●
Setting	270° potentiometer						
	11-turn potentiometer						
	teach button		●	●	●	●	●
Connection technology	M12 connector		●	●	●	●	●
	cable, 6000mm						

Sensor setting via teach button



- **The sensor is factory-adjusted for maximum operating range.**
Recommendation: teach only if the desired objects are not reliably detected.

- **Prior to teaching:**
Clear the light path to the reflector!

The device setting is stored in a fail-safe way. A reconfiguration following voltage interruption or switch-off is thus not required.

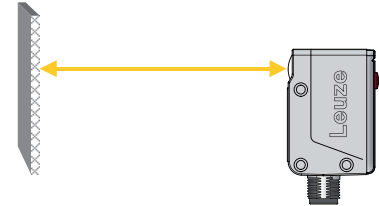

Teaching for 11% sensor sensitivity (full single bottles or tape)

- Press teach button until both LEDs flash **simultaneously**.
- Release teach button.
- Ready.



After the teaching, the sensor switches when about 11% of the light beam are covered by the object.

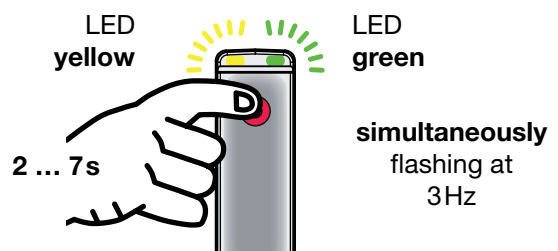

Teaching for 18% sensor sensitivity (empty single bottles)

- Press teach button until both LEDs flash **alternatingly**.
- Release teach button.
- Ready.



After the teaching, the sensor switches when about 18% of the light beam are covered by the object.



Teaching for maximum operating range (factory setting at delivery)

- Prior to teaching:
Interrupt the light path to the reflector!

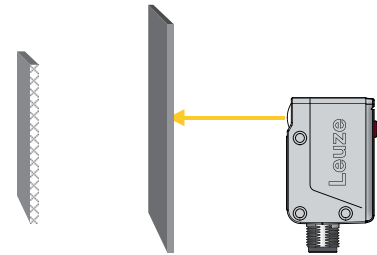

- Press teach button until both LEDs flash **simultaneously**.
- Release teach button.
- Ready.

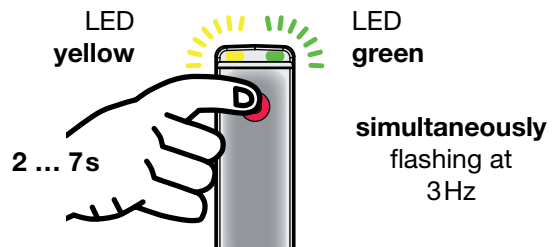

Activating/deactivating the tracking function

- Press teach button until only the green LED flashes
- Release the teach button. The yellow LED displays the tracking function status for 2s:
 - Yellow LED ON = tracking activated (factory settings)
 - Yellow LED OFF = tracking deactivated
- After 2s: ready

